

TEMPERATURE DISTRIBUTION IN A CIRCULATION GAS LENS
WITH CONSIDERATION OF GRAVITY FORCES

F. É. Gertsenshtein

UDC 535.31:532.542

We solve the differential equation for the temperature distribution function in a focusing tube of a circulation gas lens. We have derived an expression for the temperature distribution with consideration of gravity forces in the form of an expansion in Whittaker functions in a tube with infinite and finite thermal conductivity for the wall materials.

In studying thermal gas lenses we note that the law governing temperature distribution serves as the primary basis for the analysis of properties in this type of lens. Knowledge of this law makes it possible rather easily to make the transition from the temperature distribution to the distribution of the refractive index of the gas medium in the lens and, consequently, to investigate the electrodynamic characteristics of the lens. Reference [1] gives the law for the temperature distribution in a thermal gas lens without consideration of the mass forces. It was pointed out in [2-4], however, that the presence of gravity forces exert significant influence on the operation of the lens in lightguides. Consideration of the effects exerted by mass forces on the temperature distribution in a thermal gas lens will make it possible more completely to study its properties and to answer the question as to the possible ways of using lenses of this type. Let us examine the circulation gas lens (Fig. 1) proposed by Berreman, whose principle of operation is described in [4]. All of the physical processes in such a lens stand out quite clearly and can be described by rather simple mathematical means. At the same time, the derived results are easily extended to other types of thermal gas lenses. The process within the lens is regarded as steady.

A differential equation was derived in [4] for the temperature distribution function, with consideration given to gravitation within the focusing tube of the circulation gas lens. Here it was assumed that the gas flow remains laminar in the focusing portion of the lens (in the segment EF-CD). However, unlike the axisymmetric case, the gas moves as a result of the head which is a function of the coordinates r and φ (Fig. 2). It is assumed that the gas density is constant in each of the branches A'B' and AB and that it equals ρ_1 and ρ_2 , respectively, while the pressure in each of these branches is determined by the expression

$$P_{1,2} = P_0 + g\rho_{1,2}h_0 \left(1 - \frac{r}{h_0} \cos \varphi \right), \quad (1)$$

where P_0 is the pressure of the outside air.

Let us introduce the auxiliary quantity T_g

$$T_g(r, \varphi, z) = T_m - T(r, \varphi, z). \quad (2)$$

We will assume that the change in temperature in the axial direction – in comparison with its change in the transverse direction – is so small that we can assume

$$\frac{\partial^2 T}{\partial z^2} = 0. \quad (3)$$

Having introduced the dimensionless coordinates η , φ , ζ and taking into consideration (2) and (3), we present the differential equation derived in [4] for the temperature distribution in the form

$$\frac{\partial^2 T_g}{\partial r^2} + \frac{1}{\eta} \frac{\partial T_g}{\partial \eta} + \frac{1}{\eta^2} \frac{\partial^2 T_g}{\partial \varphi^2} = K(1 - b_0 \eta \cos \varphi)(1 - \eta^2) \frac{\partial T_g}{\partial \zeta}. \quad (4)$$

Bonch-Bruevich Electrical Engineering Communications Institute, Leningrad. Translated from *Inzhenerno-Fizicheskii Zhurnal*, Vol. 17, No. 1, pp. 57-64, July, 1969. Original article submitted August 19, 1968.

© 1972 Consultants Bureau, a division of Plenum Publishing Corporation, 227 West 17th Street, New York, N. Y. 10011. All rights reserved. This article cannot be reproduced for any purpose whatsoever without permission of the publisher. A copy of this article is available from the publisher for \$15.00.

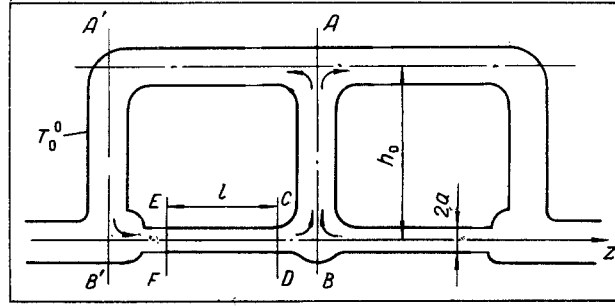

Fig. 1. Diagram of a circulation gas lens.

where K is a dimensionless constant by means of which we take into consideration the physical and geometrical parameters of the lens, with expression (1) written in the form

$$P = P_0 + g\rho h_0(1 - b_0\eta \cos \varphi). \quad (1')$$

With consideration of (1') we determine the temperature distribution in the branch $A'B'$ (for $\xi = 0$) from the Clapeyron equation by the expression

$$T_g|_{\xi=0} = (\Delta T - \delta T) + \delta T b_0 \eta \cos \varphi, \quad (5)$$

where $\Delta T = T_M - T_0$, $\delta T = gh_0/R$ is expressed in units of temperature.

We will subsequently examine a semiinfinite circular cylindrical tube (Fig. 2a). It is obvious that the gas temperature in such a tube may not be lower than T_0 , and when heated it may attain its maximum possible magnitude of T_M . In this case (5) will be a boundary condition when $\xi = 0$, while for the boundary condition at infinity, with consideration of (2), we have

$$T_g|_{\xi \rightarrow \infty} \rightarrow 0. \quad (6)$$

In the place of a real bounded structure we can introduce a semiinfinite structure into our consideration if we assume that the length l of the segments in the focusing tube has been chosen sufficiently large to assume the gas temperature in the cross section CD to be constant and equal to the temperature T_M of the metal coating. The gas temperature in each lateral cross section of such a tube must satisfy the condition of periodicity in relation to the coordinate φ , i. e.,

$$T_g(\eta, \varphi, \xi) = T_g(\eta, \varphi + 2\pi, \xi) \quad (7)$$

and, since the force of gravity is constant in the vertical direction, it must satisfy the condition of symmetry with respect to the vertical diameter:

$$T_g(\eta, \varphi, \xi) = T_g(\eta, 2\pi - \varphi, \xi). \quad (8)$$

Since the temperature T_M of the tube wall is constant, it follows from (2) that

$$T_g|_{\eta=1} = 0. \quad (9)$$

On the tube axis (when $\eta = 0$) the gas temperature must be finite

$$T_g|_{\eta=0} < \infty \quad (10)$$

and it must be independent of the angular coordinate φ . The solution of (4) is sought in the form

$$T_g = \exp\left(-\frac{\beta}{K} \xi\right) t(\eta, \varphi). \quad (11)$$

Presenting the function $t(\eta, \varphi)$ in the form of the series

$$t(\eta, \varphi) = \sum_{n=0}^{\infty} b_n^2 R_n(\eta) \cos n\varphi, \quad (12)$$

substituting (11) and (12) into (4), equating the terms that are identical functions of the angular coordinates, considering that $b_0 \ll 1$, and neglecting the terms containing b_0 in powers of two and higher, we turn to the examination of the process with respect exclusively to the single radial coordinate, which enables us to simplify the comparison of the results from this paper with those derived earlier.

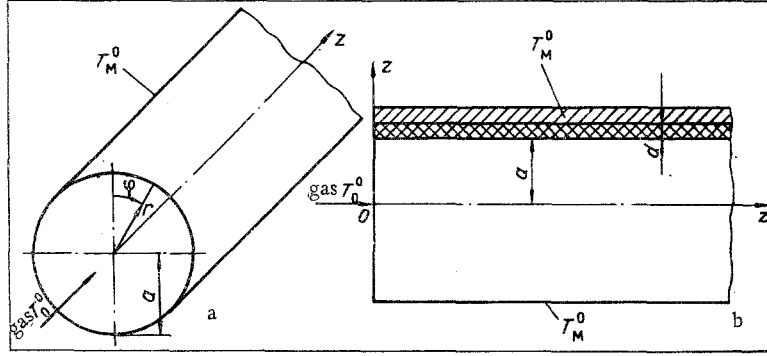

Fig. 2. Focusing tube of a circulation gas lens with infinite (a) and finite (b) thermal conductivity.

As was to be expected, in the case under consideration the zeroth approximation described by the equation

$$\eta \frac{d^2 R_0}{d\eta^2} + \frac{dR_0}{d\eta} + \beta\eta(1 - \eta^2)R_0 = 0 \quad (13)$$

coincides exactly with the equation for the temperature distribution, without consideration of gravitation (see, for example, [1]). The effect of gravitation is taken into consideration by means of the functions R_n ($n > 0$), which are solutions of the nonuniform differential equation

$$\eta \frac{d^2 R_n}{d\eta^2} + \frac{dR_n}{d\eta} + \left[\beta\eta(1 - \eta^2) - \frac{n^2}{\eta} \right] R_n = \frac{\beta}{2} \eta^2 (1 - \eta^2) R_{n-1} \quad (14)$$

and which are functions of the zero function. According to (9) and (10), we can write the boundary conditions for (13) and (14):

$$R_n|_{\eta=1} = 0 \quad (n = 0, 1, 2, \dots), \quad (15)$$

$$R_0|_{\eta=0} < \infty, \quad (16)$$

$$R_n|_{\eta=0} = 0 \quad (n = 1, 2, \dots). \quad (17)$$

It is easy to demonstrate that the solution of the boundary-value problem (13), (15), and (16) is written in the form of a series in Whittaker functions [5]

$$R_0 = \sum_{m=0}^{\infty} C_{m,0} f_{m,0} = \sum_{m=0}^{\infty} C_{m,0} \frac{1}{\eta} M_{V\sqrt{\beta_{m,0}}, 0/4, 0} (V\sqrt{\beta_{m,0}}\eta^2), \quad (18)$$

where the eigenvalues of $\beta_{m,0}$, determined from (15), are the roots of the equation

$$M_{V\sqrt{\beta}, 0/4, 0} (V\sqrt{\beta}) = 0, \quad (19)$$

while the eigenfunctions $f_{m,0}$, which correspond to the various eigenvalues, will be orthogonal in the interval $[0, 1]$, and namely:

$$\int_0^1 \eta(1 - \eta^2) f_{k,0} f_{l,0} d\eta = \begin{cases} 0, & k \neq l, \\ \left(\frac{\partial f_{m,0}}{\partial \beta_{m,0}} \frac{\partial f_{m,0}}{\partial \eta} \right)_{\eta=1}, & k = l = m. \end{cases} \quad (20)$$

We can use the method of varying constants to solve the boundary-value problem (14), (15), and (17). In this case [5],

$$R_n = \sum_{m=0}^{\infty} R_{m,n}(\beta_{m,n}, \eta) = \sum_{m=0}^{\infty} \frac{\beta_{m,n}}{2\omega(\beta_{m,n})} \left[R_n''(\beta_{m,n}, \eta) \int_0^{\eta} R_n' \eta^2 (1 - \eta^2) R_{n-1} d\eta + R_n'(\beta_{m,n}, \eta) \int_{\eta}^1 R_n'' \eta^2 (1 - \eta^2) R_{n-1} d\eta \right], \quad (21)$$

where

$$R_n' = \frac{1}{\eta} M_{V\sqrt{\beta_{m,n}}, n/4, \frac{n}{2}} (V\sqrt{\beta_{m,n}}\eta^2),$$

$$R_n'' = \frac{1}{\eta} W_{\sqrt{\beta_{m,n}/4}, \frac{n}{2}} (1 - \beta_{m,n}\eta^2),$$

$$\omega(\beta_{m,n}) = \eta \left(R_n' \frac{dR_n''}{d\eta} - R_n'' \frac{dR_n'}{d\eta} \right)$$

is a function that is independent of the radial coordinate, while the values of $\beta_{m,n}$ are roots of the equation

$$\int_0^1 R_n'(\beta, \eta) \eta^2 (1 - \eta^2) R_{n-1} d\eta = 0. \quad (22)$$

Thus, if we know the zero solution of the problem, we can find the complete solution of the problem. To derive the temperature-distribution law applicable to a gaseous medium in its final form, it is a good idea to orthogonalize the function $R_{m,n}$, which is permissible since series (21) is a sequence of linearly independent functions and the temperature distribution should be presented in the form of expansion in orthogonal functions $f_{m,n}$, determined correct to the sign by the formula [6]

$$f_{m,n} = \frac{R_{m,n} - \sum_{k=0}^{m-1} f_{k,n} \int_0^1 R_{m,n} f_{k,n} d\eta}{\left\{ \int_0^1 \left[R_{m,n} - \sum_{k=0}^{m-1} f_{k,n} \int_0^1 R_{m,n} f_{k,n} d\eta \right]^2 d\eta \right\}^{1/2}}. \quad (23)$$

Assuming the orthogonalization process to have been completed, utilizing the conditions of orthogonality for the trigonometric functions and the functions $f_{m,n}$ ($n = 0, 1, 2, \dots$), as well as boundary condition (5), we finally obtain

$$T_g = (\Delta T - \delta T) \sum_{m=0}^{\infty} \exp\left(-\frac{\beta_{m,0}}{K} \zeta\right) \frac{\int_0^1 \eta (1 - \eta^2) f_{m,0} d\eta}{\left(\frac{\partial f_{m,0}}{\partial \beta_{m,0}} \frac{\partial f_{m,0}}{\partial \eta} \right)_{\eta=1}} f_{m,0}(\beta_{m,0}, \eta)$$

$$+ \delta T b_0 \sum_{m=0}^{\infty} \exp\left(-\frac{\beta_{m,1}}{K} \zeta\right) \frac{\int_0^1 \eta f_{m,1} d\eta}{\int_0^1 f_{m,1}^2 d\eta} f_{m,1}(\beta_{m,1}, \eta) \cos \varphi. \quad (24)$$

In certain cases, from purely technological considerations, it is more convenient to fabricate the circulation gas lens from a glass tube whose outside surface – with the exception of the insulated "windows" – is metal coated. In this case, between the heated metal tube which exhibits a constant temperature T_m and the gas flow we have a glass spacer which is made of a material that exhibits a comparatively low coefficient of thermal conductivity. A unique temperature distribution is established within the glass, and this must be taken into consideration in analyzing the temperature regime within the gas. Even in this case we will assume the operational regime for the lens to be such that its focusing point can be replaced by a semiinfinite tube (Fig. 2b). The difference from the problem considered above lies in the variation in the boundary conditions at the wall of the tube. In analogy with (2), if the temperature in the glass is introduced by means of the relationship

$$T_{g1}(\eta, \varphi, \zeta) = T_{g1} - T(\eta, \varphi, \zeta), \quad (25)$$

in the steady-state regime condition (9) must be replaced by the condition at the glass–metal boundary, i.e.,

$$T_{g1}|_{\eta=b=1+\frac{d}{a}} = 0 \quad (26)$$

and the conditions at the gas–glass boundary

$$T_{g1}|_{\eta=1} = T_g|_{\eta=1}, \quad (27)$$

$$\lambda_{g1} \frac{\partial T_c}{\partial \eta} \Big|_{\eta=1} = \lambda_g \frac{\partial T_g}{\partial \eta} \Big|_{\eta=1}.$$

Relationships (5)-(8) and (10) remain valid even in this case, while for the glass it becomes necessary to introduce yet another condition which for the gas is identical to (6), i.e.,

$$T_{\text{gl}}|_{z \rightarrow \infty} \rightarrow 0. \quad (6')$$

Condition (6') corresponds to the practically utilized case of leveling out the temperature in the central branch AB of the lens [7]. The length of the focusing tube at which this is possible is, of course, increased in comparison with metal tubes, of which more will be said in detail later on.

We know [8] that in the steady-state regime the temperature distribution in the glass is described by the Laplace equation, i.e.,

$$\frac{\partial^2 T_{\text{gl}}}{\partial \xi^2} + \frac{\partial^2 T_{\text{gl}}}{\partial \eta^2} + \frac{1}{\eta} \frac{\partial T_{\text{gl}}}{\partial \eta} + \frac{1}{\eta^2} \frac{\partial^2 T_{\text{gl}}}{\partial \varphi^2} = 0, \quad (28)$$

whose solution, with consideration of (7), (8), and (6'), will be

$$T_{\text{gl}} = \sum_{n=0}^{\infty} \exp(-\gamma \xi) [C_n' J_n(\gamma \eta) + C_n'' N_n(\gamma \eta)] \cos n\varphi. \quad (29)$$

The temperature distribution within the gas, as above, is described by Eq. (4). Consequently, in this case the form of the zero solution (18) is retained, as well as that of the additional solution (21) for the radial function. However, unlike the above, the eigenvalues of the boundary-value problem under consideration are found as roots of the determinant:

$$\begin{vmatrix} J_0\left(\frac{\gamma}{K}\right) - q_0 N_0\left(\frac{\gamma}{K}\right) & -R_0(\gamma, 1) \\ \frac{\gamma}{K} \lambda_{\text{gl}} \left[J_0'\left(\frac{\gamma}{K}\right) - q_0 N_0'\left(\frac{\gamma}{K}\right) \right] & -\lambda_{\text{g}} \frac{dR_0}{d\eta} \Big|_{\eta=1} \end{vmatrix} = 0 \quad (30)$$

for the zero solution and

$$\begin{vmatrix} J_n\left(\frac{\gamma}{K}\right) - q_n N_n\left(\frac{\gamma}{K}\right) & -R_n'(\gamma, 1) \\ \frac{\gamma}{K} \lambda_{\text{gl}} \left[J_n'\left(\frac{\gamma}{K}\right) - q_n N_n'\left(\frac{\gamma}{K}\right) \right] & -\lambda_{\text{g}} \frac{dR_n'}{d\eta} \Big|_{\eta=1} \end{vmatrix} = 0 \quad (31)$$

for the additional solution, where

$$q_n = \frac{J_n\left(\frac{\gamma}{K} b\right)}{N_n\left(\frac{\gamma}{K} b\right)}.$$

In this case the functions $R_0(\gamma_{m,0}, \eta)$ no longer corresponds to the orthogonality condition (20).

Therefore, in order to derive a final expression for the temperature-distribution function, on the basis of the radial functions R_n ($n = 0, 1, \dots$) we have to construct a system of orthogonal functions $\psi_{m,n}(\gamma_{m,n}, \eta)$, using (23), and we have to write the sought solution with consideration of (5) in the form of series in functions of $\psi_{m,n}$. Having carried out this process, for the temperature distribution in the gas we find

$$\begin{aligned} T_{\text{g}} = & (\Delta T - \delta T) \sum_{m=0}^{\infty} \exp\left(-\frac{\gamma_{m,0}}{K} \xi\right) \frac{\int_0^1 \eta(1-\eta^2) \psi_{m,0} d\eta}{\int_0^1 \psi_{m,0}^2 d\eta} \psi_{m,0}(\gamma_{m,0}, \eta) \\ & + \delta T b_0 \sum_{m=0}^{\infty} \exp\left(-\frac{\gamma_{m,1}}{K} \xi\right) \frac{\int_0^1 \eta \psi_{m,1} d\eta}{\int_0^1 \psi_{m,1}^2 d\eta} \psi_{m,1}(\gamma_{m,1}, \eta) \cos \varphi. \end{aligned} \quad (32)$$

Thus, unlike the axisymmetric case in which gravity forces are not taken into consideration [7], in this case we note disruption of symmetry for the temperature distribution relative to the axis of the focusing

tube of the lens. In analogy with [7], if we assume the minimum absolute temperature to be the axial (in the optical sense) value for the temperature at each cross section of the tube, as we can see from (24) the effect of gravitation leads to a shifting of the optical lens axis relative to its geometric axis, and this displacement varies as a function of the axial coordinate. Moreover, the fact that the temperature-distribution function contains a term with a cosinusoidal function of the amplitude coordinate φ , which represents an infinite series in odd powers of the radial coordinate, indicates the different temperature distributions in the upper and lower halves of the focusing tube, and in the final analysis this must result in the appearance of odd aberrations in the image of the light spot.

The effect of the glass is manifested primarily in the magnitude of the eigenvalues of $\gamma_{m,n}$, which will be smaller than the corresponding values of $\beta_{m,n}$ and they will be functions of the thermal conductivity of the spacer material and of the type of gas. This characterizes a slower rate of increase for the temperature in the gas. Knowing the quantity $\gamma_{m,n}$ and $\beta_{m,n}$ makes it possible to correct the length of the focusing segments of a lens with and without glass, these lengths being those at which it is possible to make the transition to an examination of a semiinfinite structure. It is obvious that in this case the focusing effect of the lenses will be identical for both designs, since that effect is characterized by the temperature differences across the length of the focusing tube.

However, generally speaking, there is an exponential variation in the temperature at the gas-glass boundary. Appropriate choice for the thickness of the glass spacer can make this law differ little from the linear. In this case the results from [9] are applicable to such a structure with a high degree of accuracy, i. e., with a glass tube placed between the heated metal and the laminar gas flow it becomes possible to alter the characteristics of the optical bundle.

The numerical processing of these results is possible with the aid of an electronic digital computer.

As was pointed out in [4], the effect of gravitation can be reduced by lowering the ratio of the light-beam radius to the radius of the focusing tube. From these solutions we see that the gravitation effect can also be controlled by means of the parameter b_0 , i. e., by perfecting the design of the lens.

If it becomes necessary to take into consideration the gravity forces and to perform thermal-engineering calculations, these results can be extended to other systems by selecting an analog for the parameter b_0 .

NOTATION

$\eta = r/a$	is the dimensionless radial coordinate;
$\zeta = z/a$	is the dimensionless axial coordinate;
T_m	is the temperature of the wall of the focusing tube;
T_0	is the temperature of the ambient medium;
g	is the acceleration of free fall;
$b_0 = a/h_0$,	where h_0 is the height of the lens;
$K = 2wc\rho/\pi a\lambda_g$	is a dimensionless constant;
w	is the volumetric gas flow rate through the focusing tube;
c_p	is the heat capacity of the gas constant pressure;
ρ	is the gas density;
R	is the universal gas constant;
J and N	are Bessel and Neumann functions;
λ_g and λ_{gl}	are the thermal conductivities of the gas and the glass, respectively.

LITERATURE CITED

1. D. Marcuse, Trans. IEEE, MTT-13, No. 6, 734 (1965).
2. G. Gubo, Elektronika, No. 10, 6 (1966).
3. W. H. Heier, Trans. IEEE, MTT-13, No. 6, 740 (1965).
4. F. É. Gertsenshtein and A. Z. Fradin, Trudy Uchebnykh Institutov Svyazi, No. 41 (1968).
5. E. Kamke, Handbook on Ordinary Differential Equations [Russian translation], Fizmatgiz (1965).
6. G. Alexis, Problems in the Convergence of Orthogonal Series [Russian translation], IL (1963).
7. D. Marcuse and S. E. Miller, BSTJ, 43, Part 2, No. 4, 1759 (1964).
8. V. P. Isachenko et al., Heat Transfer [in Russian], Energiya (1965).
9. B. M. Berkovskii, et al., Inzhen.-Fiz. Zh., 13, No. 4, 425 (1967).